

Wm. E. Williams No. B15G Class 150 Flanged OS&Y Bolted Bonnet Globe Valve ASTM B62

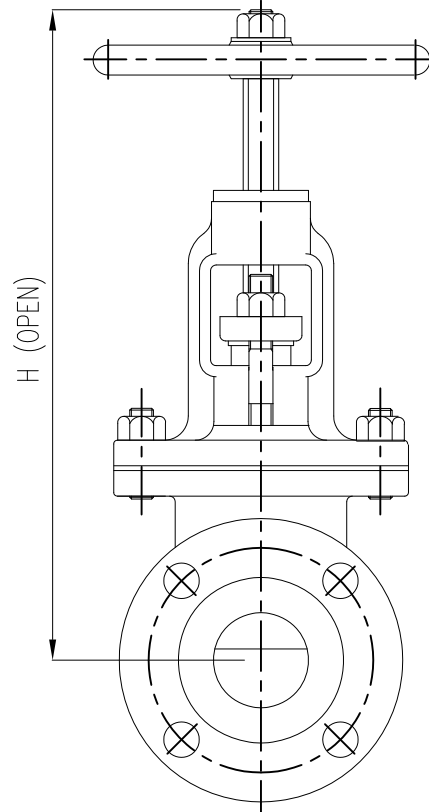
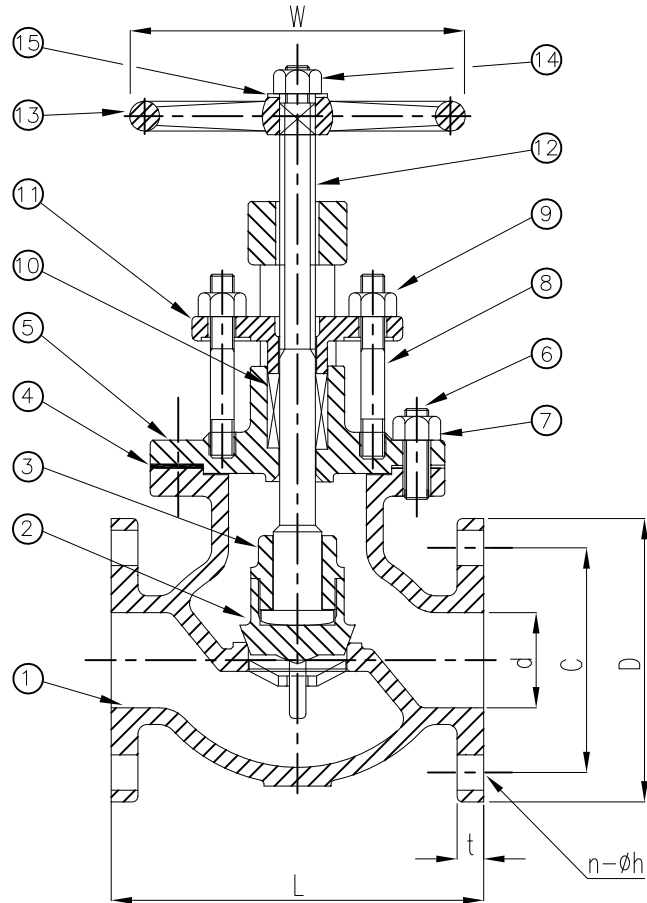

BILL OF MATERIALS			
NO.	PART NAME	MATERIALS	Q'TY
1	BODY	ASTM B62	1
2	DISC	ASTM B62	1
3	DISC NUT	ASTM B124	1
4	GASKET	ASTM B62 (SEE NOTE 3)	1
5	BONNET	ASTM B62	1
6	BONNET STUD	ASTM B16	1 SET
7	BONNET NUT	ASTM B16	1 SET
8	GLAND STUD	ASTM B16	2
9	GLAND NUT	ASTM B16	2
10	PACKING	TFE (SEE NOTE 1)	1
11	GLAND FLANGE	ASTM B62	1
12	STEM	ASTM B124	1
13	HANDWHEEL	ASTM A197	1
14	HANDWHEEL NUT	ASTM B16	1
15	WASHER	BRASS	1

NOTE:

1. ALSO AVAILABLE IN GRAPHITE. PLEASE SPECIFY WHEN ORDERING.
2. STOP CHECK DESIGN. (OPTIONAL)
3. ALTERNATE MATERIALS AVAILABLE.
4. BOTTOM GUIDE DESIGN (2" AND UP)

SIZE	d	L	D	C	t	H	n-øh	W
1-1/2	1.50	6.50	5.00	3.87	0.437	9.25	4-0.62	5.50
2	2.00	7.00	6.00	4.75	0.500	10.94	4-0.75	7.12
2-1/2	2.50	8.50	7.00	5.50	0.562	12.41	4-0.75	7.12
3	3.00	9.12	7.50	6.00	0.625	14.00	4-0.75	7.87
4	4.00	12.00	9.00	7.50	0.687	14.00	8-0.75	8.81
5	5.00	14.00	10.00	8.50	0.750	16.25	8-0.87	12.41
6	6.00	16.62	11.00	9.50	0.813	18.00	8-0.87	14.00
8	8.00	19.50	13.50	11.75	0.938	21.25	8-0.87	14.00

NO.	DATE	DESCRIPTION	PRP'D	REV'D	APP'D	APPLICABLE STANDARDS	INSPECTION & TEST: MSS-SP80	MATERIAL: ASTM B62	UNITS: Inch, mm
△	5/17/16	RELEASED	F.J.	R.P.	R.P.	MSS-SP-6 MSS-SP-25	SHELL HYDRO 350PSI	CLASS: 150 DATE: 01/01/12	SCALE: N.T.S.
△	1/1/12	RELEASED	F.J.	R.P.	R.P.	MSS-SP-9 MSS-SP-82	SEAT AIR -	SIZE: 1-1/2" - 8"	FIG. No.: B15G
						DESIGNED ANSI B16.24	BACK SEAT HYDRO 225PSI	DRAWN BY: F. J.	
								CHK'D & APR'D BY: R.P.	REV: 2 DWG No.: 20GL120006-20

WILLIAM E. VALVE CORPORATION
 39-52 REVIEW AVENUE LONG ISLAND CITY, NY 11101
 TEL: 718-392-1660 FAX: 718-729-5106

TITLE: CAST BRONZE BOLTED BONNET GLOBE VALVE CLASS 150 - OS&Y - ASTM B62