

Class 1500 Welded Bonnet Lift Check Valve A105N (API Trim 8) NACE

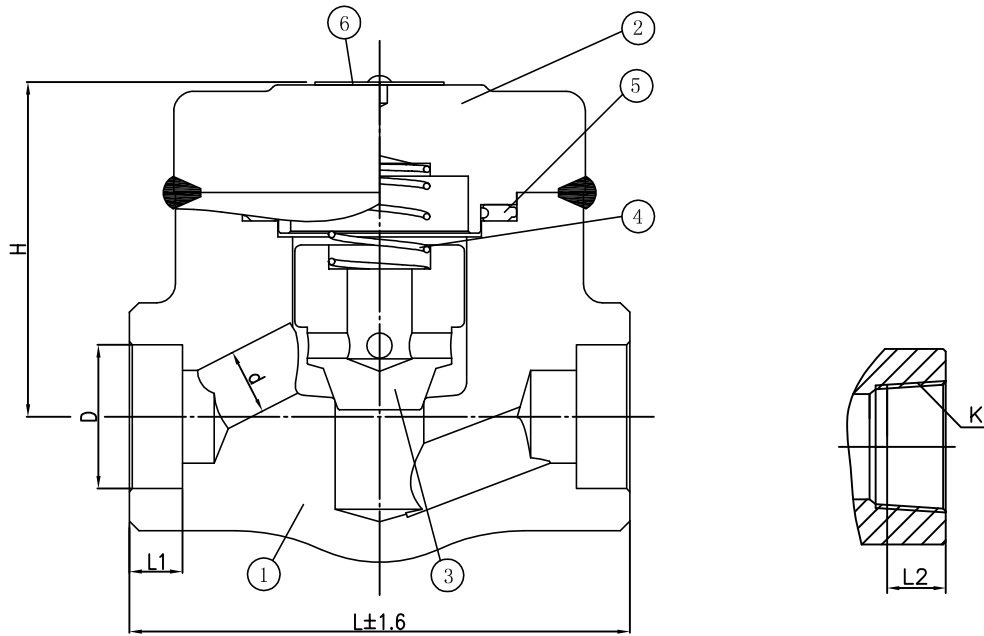

BILL OF MATERIALS

ITEM	PART NAME	MATERIAL	QTY
1	BODY	A105N + HF	1
2	COVER	A105N	1
3	DISC	A276-420	1
4	SPRING	304 SS	1
5	GASKET	F304+Graphite	1
6	NAME PLATE	STAINLESS STEEL	1

VALVE SIZE		L	d	D	L1	H	K	L2
DN	IN							
15	1/2"	111	Ø10	Ø21.8	10	98	1/2"	Ø15.5
20	3/4"	111	Ø14	Ø27.2	13	98	3/4"	Ø16.5
25	1"	120	Ø19	Ø33.9	13	104	1"	Ø19.5
32	1 1/4"	152	Ø25	Ø42.7	13	120	1 1/4"	Ø21
40	1 1/2"	172	Ø29	Ø48.8	13	140	1 1/2"	Ø21
50	2"	220	Ø35	Ø61.2	16	158	2"	Ø23

NO.	DATE	DESCRIPTION	PRP'D	REV'D	APP'D	MARKING SYSTEM	MSS-SP-25	INSPECTION & TEST: API 598
						FACE TO FACE	API 602	SHELL HYDRO 5598PSI
						WALL THICKNESS	BS1868	SEAT AIR 80PSI
						DESIGNED	API 602	BACK SEAT HYDRO 4100PSI
								NACE MR 0175

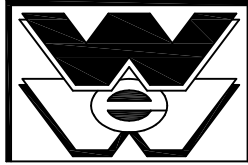

WILLIAMS
VALVE CORPORATION

38-52 REVIEW AVENUE
LONG ISLAND CITY, NY 11101

WWW.WILLIAMSVALVE.COM

TEL: 718-392-1660
FAX: 718-729-5106

TITLE: FORGED STEEL WELDED BONNET
LIFT CHECK VALVE - CLASS 1500 - API TRIM 8

MATERIAL: A105N		UNITS: Inch, mm	
CLASS: 1500	DATE: 01/01/12	SCALE: N.T.S.	
SIZE: 1/2 - 2"		FIG. No.: F1501LTXS-2N WB (sw. by thr. ends) F1501LSW-2N WB (sw. ends) F1501LT-2N WB (thr. ends)	
DRAWN BY: F.J.		CHK'D & APR'D BY: R.P.	
REV: 1		DWG No.: 50LC120218	