

Wm. E. Williams No. 901W2N Class 900 BW Swing Check Valve A216 WCB (API Trim 8) NACE

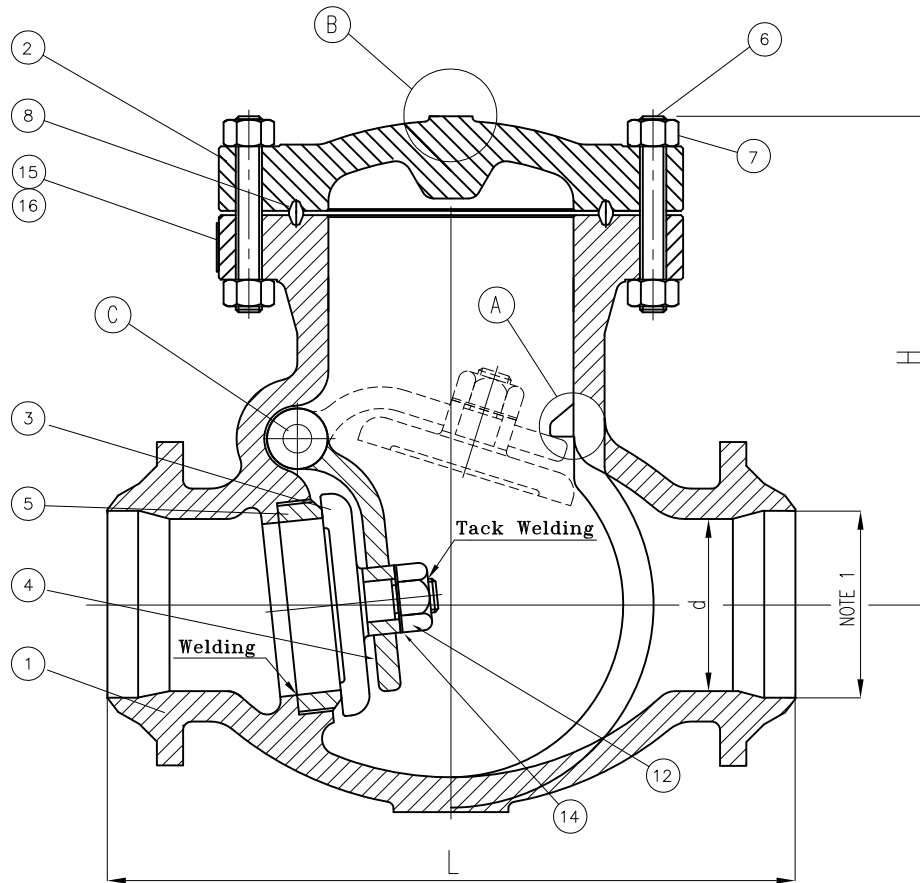

BILL OF MATERIALS			
NO.	PART NAME	MATERIAL	Q'TY
1	BODY	A216Gr WCB	1
2	COVER	A216Gr WCB	1
3	DISC	A216 GR WCB + 13Cr Faced	1
4	ARM	A216Gr WCB	1
5	SEAT RING	A105N + HF	1
6	COVER BOLT	A193Gr B7M	1SET
7	COVER NUT	A194Gr 2HM	1SET
8	GASKET, RING JOINT	304 + GRAPHITE	1
9	PIN GASKET	410	1
10	HINGE PIN	A479Gr 410	1
11	HINGE BOLT	A193Gr B7M	1
12	DISC NUT	A194Gr 2HM	1
13	EYE BOLT	A193Gr B7M	1
14	WASHER	STEEL	1
15	NAME PLATE	STAINLESS STEEL	1
16	RIVET	STAINLESS STEEL	2

NOTE:
1. SPECIFY PIPE SCHEDULE No. REQUIRED.

SIZE	d	L	H
2.00	2.00	14.50	9.25
3.00	3.00	15.00	9.50
4.00	4.00	18.00	11.00
6.00	6.00	24.00	13.75
8.00	7.88	29.00	18.00

Remark: Larger sizes available upon request.

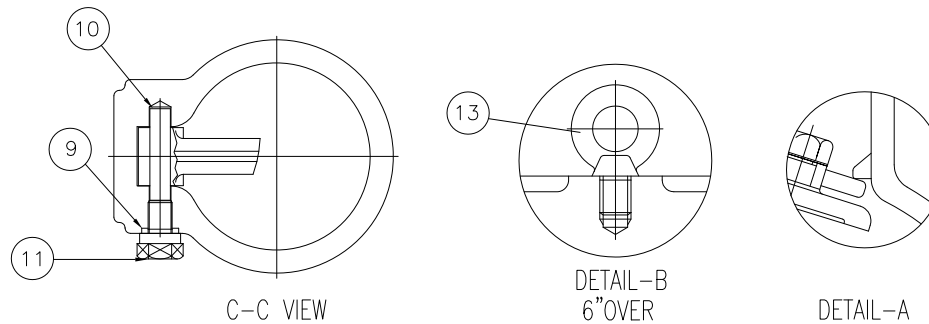

					MARKING SYSTEM	MSS-SP-25	INSPECTION & TEST: API 598	MATERIAL: ASTM A216 GR.WCB	UNITS: Inch, mm							
					BUTTWELD ENDS	ANSI B16.25	SHELL HYDRO 3350PSI	CLASS: 900	DATE: 01/01/12							
					FACE TO FACE	ANSI B16.10	SEAT AIR 80PSI	SIZE: 2" - 8"	SCALE: N.T.S.							
					WALL THICKNESS	ANSI B16.34	BACK SEAT HYDRO 2450PSI	DRAWN BY: F.J.	FIG. No.: 901W-2N							
					NO.	DATE	DESCRIPTION	PRP'D	REV'D	APP'D	DESIGNED	BS1868, ANSI B16.34	NACE MR 0175	CHK'D & APR'D BY: R.P.	REV: 1	DWG No.: 60SC120134

WILLIAM E. WILLIAMS VALVE CORPORATION
 38-52 REVIEW AVENUE LONG ISLAND CITY, NY 11101
 TEL: 718-392-1660 FAX: 718-729-5106
 WWW.WILLIAMSVALVE.COM

TITLE: CAST STEEL SWING CHECK VALVE CLASS 900 - API TRIM 8 - BUTTWELD