

Class 1500 Welded Bonnet Ball Check Valve A105N (API Trim 8) NACE

BILL OF MATERIALS

ITEM	PART NAME	MATERIAL	QTY
1	BODY	A105N + HF	1
2	COVER	A105N	1
3	BALL DISC	A276-420	1
4	SPRING	304 SS	1
5	GASKET	F304+Graphite	1
6	NAME PLATE	STAINLESS STEEL	1

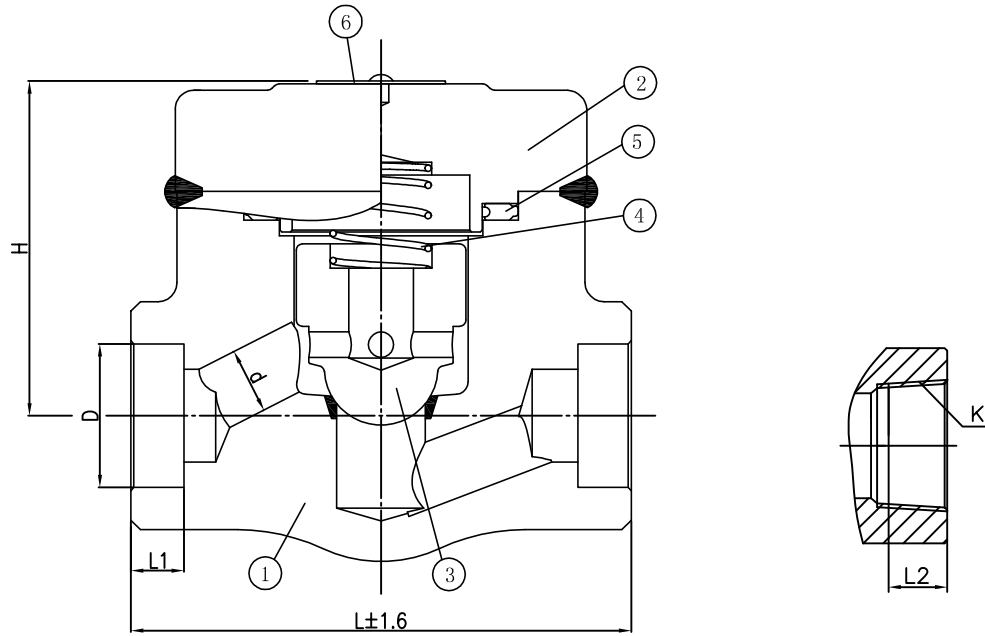

VALVE SIZE		L	d	D	L1	H	K	L2
DN	IN							
15	1/2"	111	Ø10	Ø21.8	10	98	1/2"	Ø15.5
20	3/4"	111	Ø14	Ø27.2	13	98	3/4"	Ø16.5
25	1"	120	Ø19	Ø33.9	13	104	1"	Ø19.5
32	1 1/4"	152	Ø25	Ø42.7	13	120	1 1/4"	Ø21
40	1 1/2"	172	Ø29	Ø48.8	13	140	1 1/2"	Ø21
50	2"	220	Ø35	Ø61.2	16	158	2"	Ø23

WILLIAM E. WILLIAMS
VALVE CORPORATION

WWW.WILLIAMSVALVE.COM

38-52 REVIEW AVENUE
LONG ISLAND CITY, NY 11101

TEL: 718-392-1660
FAX: 718-729-5106

TITLE: FORGED STEEL WELDED BONNET
BALL CHECK VALVE - CLASS 1500 - API TRIM 8

MATERIAL: A105N UNITS: Inch, mm

CLASS: 1500 DATE: 01/01/12 SCALE: N.T.S.

SIZE: 1/2 - 2" DRAWN BY: F.J.

FIG. No.: F1501BTXS-2N WB (sw. by thr. ends)
F1501BSW-2N WB (sw. ends)
F1501BT-2N WB (thr. ends)

CHK'D & APR'D BY: R.P. REV: 1 DWG No.: 50LC120274

NO.	DATE	DESCRIPTION	PRP'D	REV'D	APP'D	MARKING SYSTEM	MSS-SP-25	INSPECTION & TEST: API 598
						FACE TO FACE	API 602	SHELL HYDRO 5598PSI
						WALL THICKNESS	BS1868	SEAT AIR 80PSI
						DESIGNED	API 602	BACK SEAT HYDRO 4100PSI
								NACE MR 0175

1/1/12 ISSUED FOR PROPOSAL